

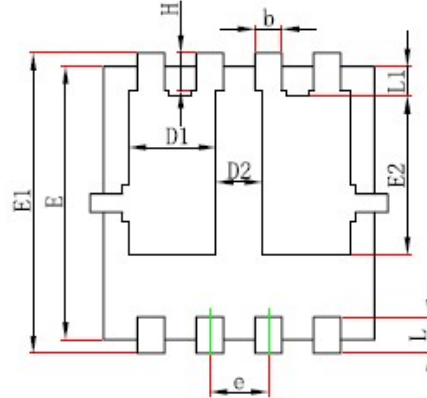

PPAK3x3-8L PACKAGE OUTLINE

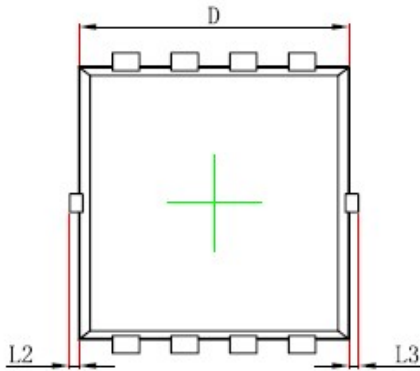

Top View  
[顶视图]

Bottom View  
[背视图]

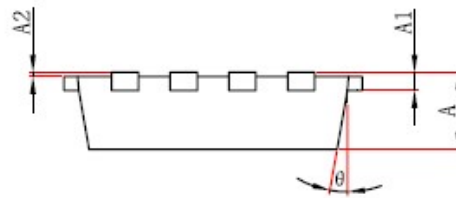

Side View  
[侧视图]

SYMBOL	MILLIMETERS		
	MIN	NOM	MAX
A	0.650	0.750	0.850
A1	0.152 REF.		
A2	0-0.05		
b	0.200	0.300	0.400
D	2.900	3.000	3.100
D1	0.935	1.035	1.135
D2	0.280	0.380	0.480
E	2.900	3.050	3.200
E1	3.150	3.300	3.450
E2	1.535	1.735	1.935
e	0.65 BSC		
H	0.315	0.415	0.515
L	0.300	0.400	0.500
L1	0.180	0.330	0.480
L2	0-0.100		
L3	0-0.100		
$\theta$	9°		13°