



擎力科技股份有限公司

SYNC POWER CORP

COMPANY PROFILE

WWW.SYNCPower.COM



COMPANY BASIC DATA

- Officially formed in Jan., 2004
- Total registered capital investment: USD3.5 millions
- Analog IC Design company
 - Design Office in USA and Taiwan
- Number of employee: 26
 - 50% are R/D related
- Owns five patents and two more are in applying
- ISO9001-2000 certified



PRODUCT APPLICATION

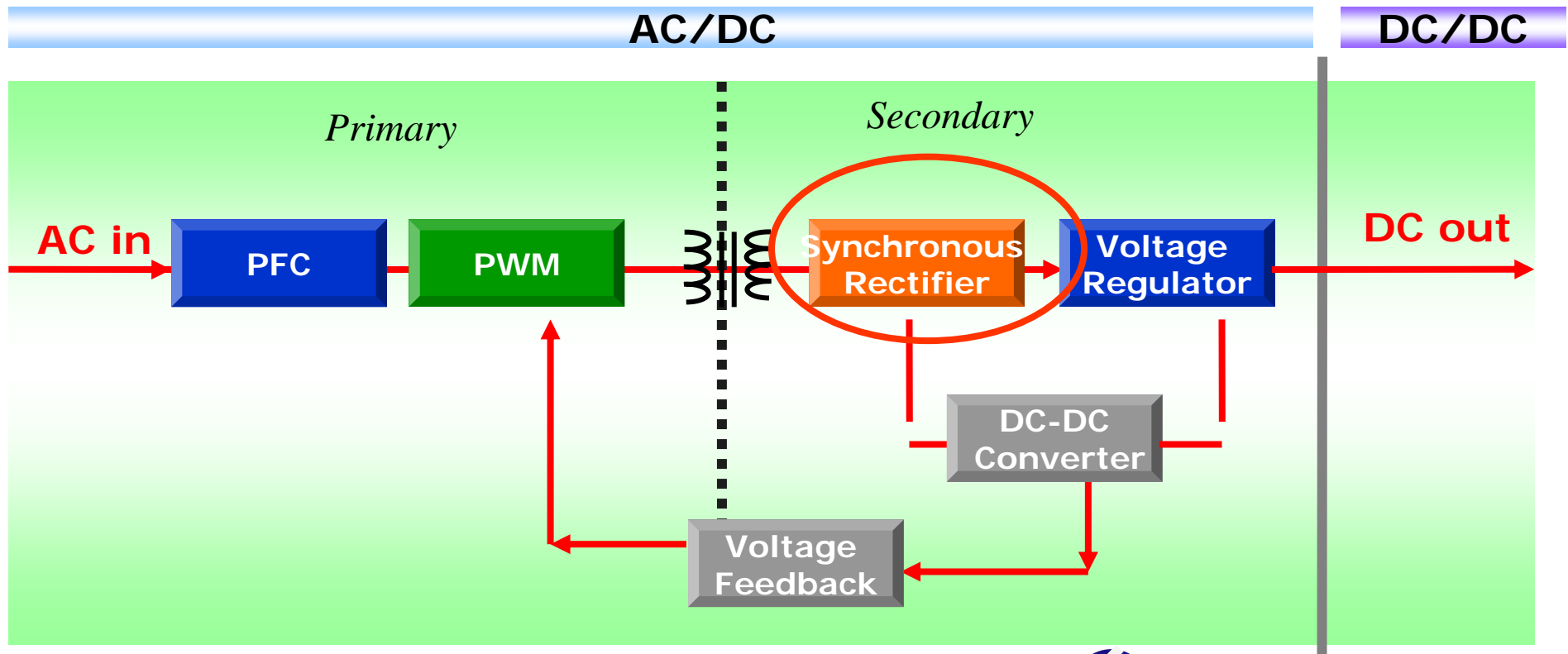

7F-2, 3-1 Park St. Nankung District,
Taipei, Taiwan



擎力科技股份有限公司



PRODUCT LINES

- IC
 - Synchronous Rectifier Controller
 - PWM
 - Shunt Regulator
- MOSFET
- ESD
- Over 200 products





2010 Major Package Capacity

- SOT23: 20kk/30kk(2011)
- SOT23/5/6:3 ~ 5kk
- SOT223:5 ~ 10kk
- SOP8:2 ~ 5kk
- TO252-3/5:2 ~ 5kk
- TO220/263:2 ~ 5kk



PRODUCTS

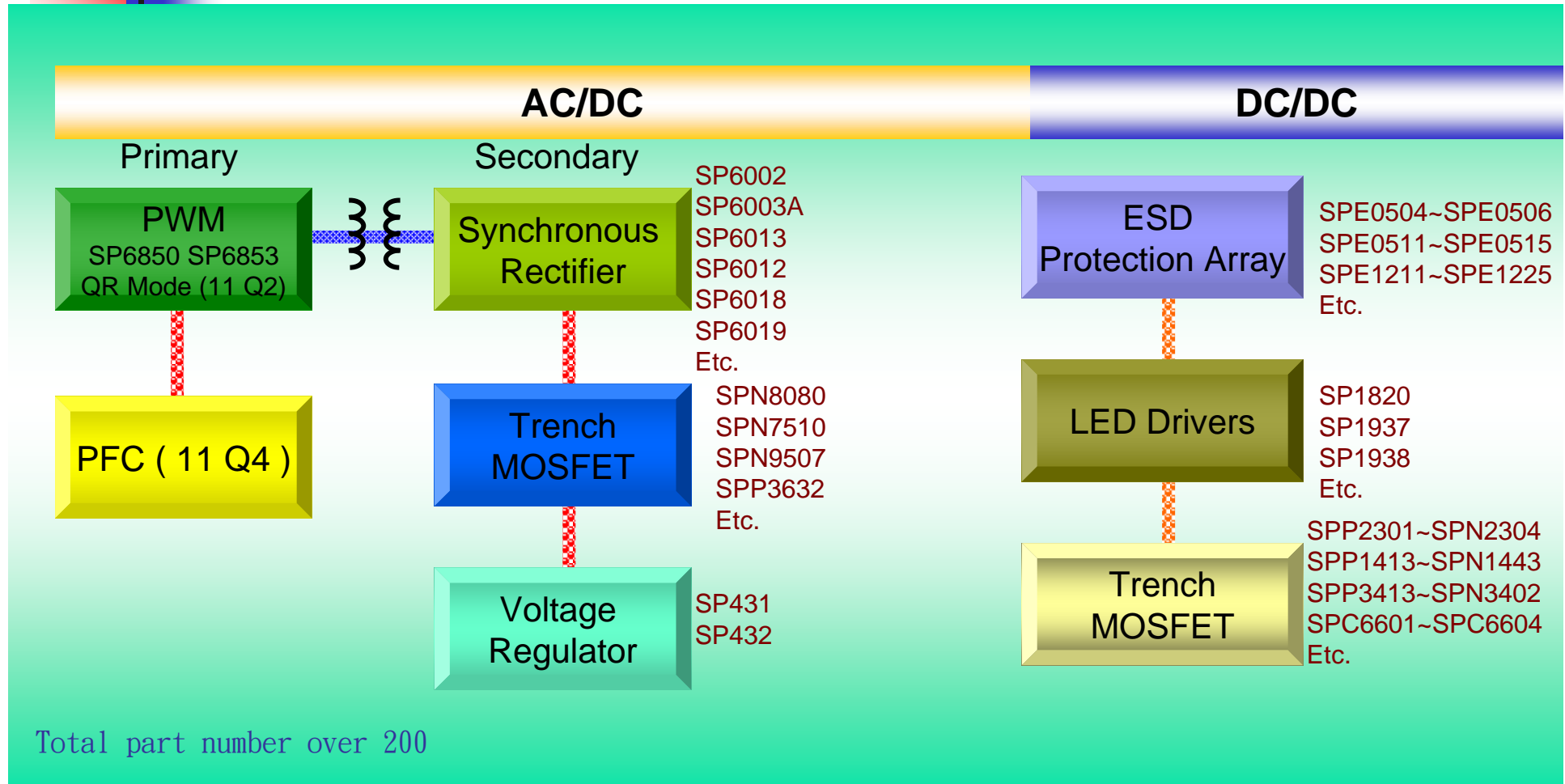

7F-2, 3-1 Park St. Nankung District,
Taipei, Taiwan



擎力科技股份有限公司



APPLICATIONS

- Switching Mode Power Supply
 - PC、NB
 - Server
 - LCD TV
 - DC/DC Converter
- Battery Powered Products
 - Cell Phone
 - PDA
 - DSC
 - MP3/4





CORE TECHNOLOGY (PATENTS)

- US Patents: 5,736,890; 6,038,150; 6,055,170; 6,456,106; 7,436,233; 8,041,524
- SR IC
 - Prediction Technology
 - CCM and DCM Tracking
 - Noise Detection
 - ON-Delay Time Adjustment
- PWM IC
 - Integrate Pulse Mode
- PFC IC
 - Slope Mode Technology



QUALITY SYSTEM

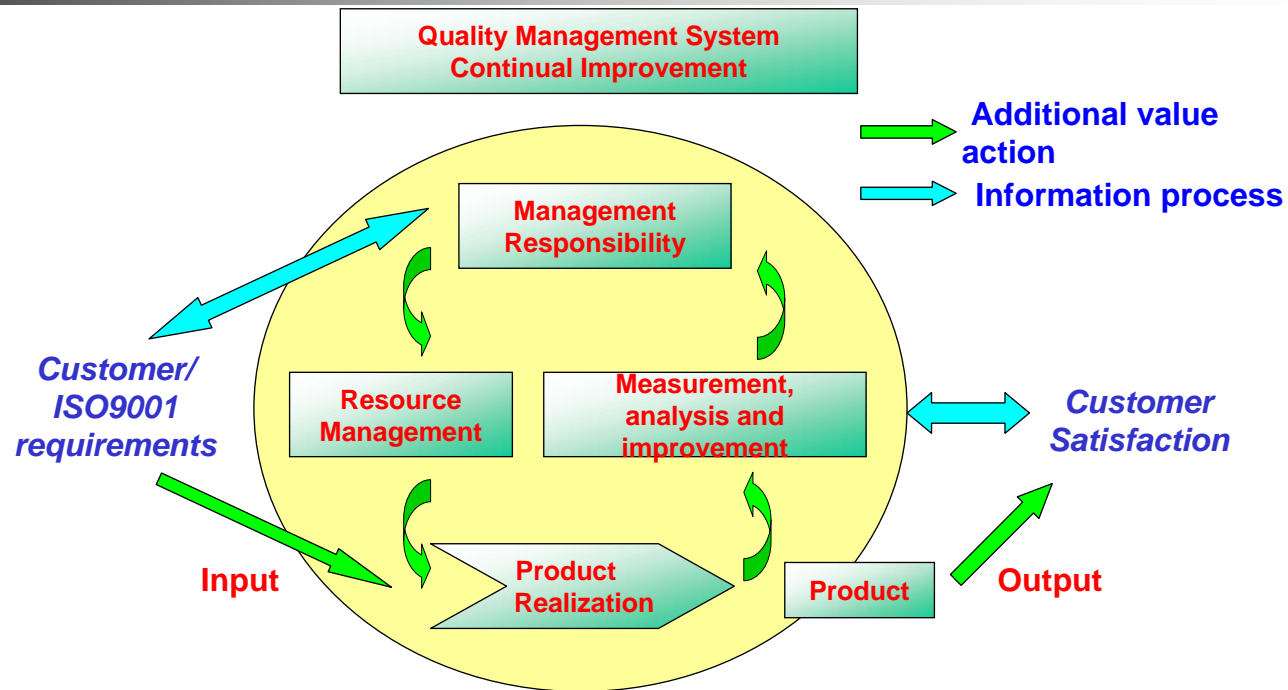

- **Do it right first time**
- **Provide customer needed products and services**
- **Continue improvement to upgrade quality**





MAJOR SUBCOM

✦ Wafer Foundry

- Vanguard International Semiconductor Corp. (V.I.S)
- MOSEL (MOSEL)

✦ Wafer Testing

- Micro Silicon Elecs. Corp. (M.S.E)
- Mega Chen Enterprises Co. LTD (M.C.E)

✦ Assembly & FT

- Jiangsu Changjian Electronics Technology Co. LTD. (J.C.E)
- GTM Corporation (GTM)

